



# **mr** MOBILE ROBOTS



ADVANCED INTRALOGISTICS



BY UNITED ROBOTICS GROUP

## MobilePalletizing



INTEGRATING PRODUCTIVITY

**PLUG & PALLETIZE**

**MOBILE & FLEXIBLE**

**AGV COMPATIBLE**

**3 COBOT VERSIONS**

powered by  
**UNIVERSAL ROBOTS**

**CE APPROVED & CERTIFIED  
INDUSTRIAL APPLICATION**



## MobilePalletizing

### **PLUG & PRODUCE AUTOMATION FOR YOUR PALLETIZING READY FOR IMMEDIATE USE IN INDUSTRY, TRADE & SERVICE**

Automate burdensome tasks related to packaging or confectioning. Thanks to the integrated collaborative lightweight robot, our Cobot Palletizers do not require a bulky protective housing and their compactness requires little space only. The smart design allows for changing locations in your production as required, while the programming-free, intuitive operation enables quick deployment.

Thanks to the modular design of the three basic versions with payloads of up to 12.5 kg, 20 kg and 30 kg - with exclusive use of Cobots by Universal Robots - the system can be configured individually with optional accessories and used in a wide variety of different industries and business models.

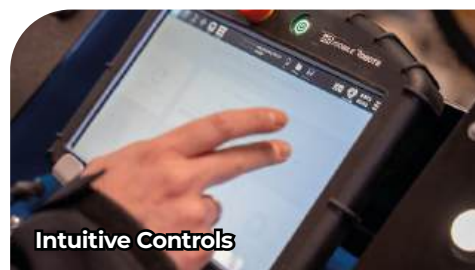

**Intuitive Controls**



**Config. Gripper with tactile Bumper**



**Option: Conveyor at choice**

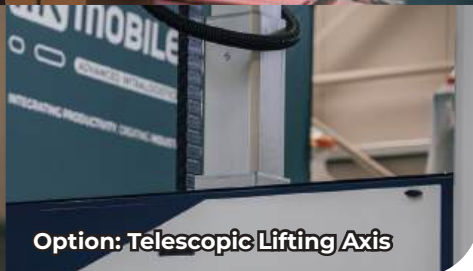

**Option: Telescopic Lifting Axis**

### **FEATURES, FACTS & BENEFITS YOUR EFFICIENCY ADDED VALUES**

#### **• EFFECTIVE & SUSTAINABLE**

Complete automation of physically strongly demanding manual activities

#### **• COMPACT & INTEGRATIVE**

Smooth integration into existing process layouts for optimal workflow

#### **• MOBILE & FLEXIBLE**

Compact design enables change of location as required

#### **• COLLABORATIVE & SAFE**

CE-certified HRC application with high acceptance by employees

#### **• INDIVIDUALLY CUSTOMIZABLE**

Versatile configurable & optionally expandable - e.g. freely selectable end-of-arm tool for single or multiple handling, lifting axis, conveyor or safety scanner

#### **• EASE OF USE**

Intuitive control, user-friendly operation

**ALL INFOS & TECHNICAL DATA ALSO AVAILABLE ONLINE:**



**FREE PACK PATTERNS**

**OFFLINE PROCESSING**

**DRAG & DROP EDIT**

**FLEXIBLE STACKING:**

With an intuitive Palletizing Software you can simply insert intermediate layers and vary your palletizing pattern layer by layer as required.

**CUSTOMIZABLE PALLETIZING FOR YOUR FLEXIBLE WORKFLOW**

**TECHNICAL DATA**

**BASIC TYPE UR 10 (12.5 kg payload)**

**BASIC TYPE UR 20 (25 kg payload)**

**BASIC TYPE UR 30 (35 kg payload)**

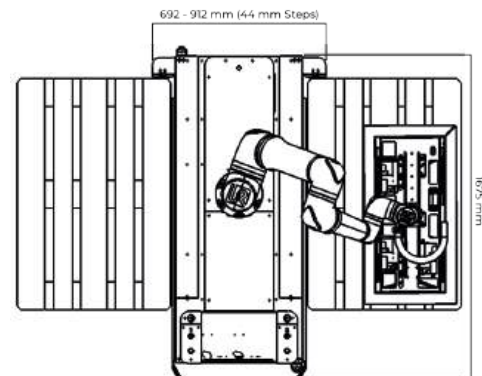
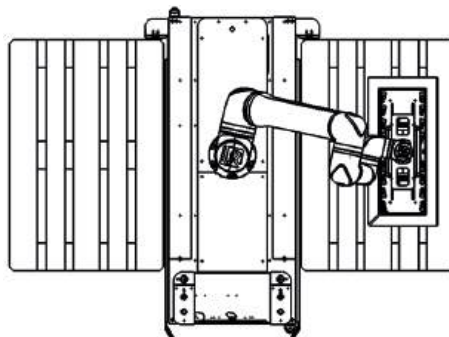
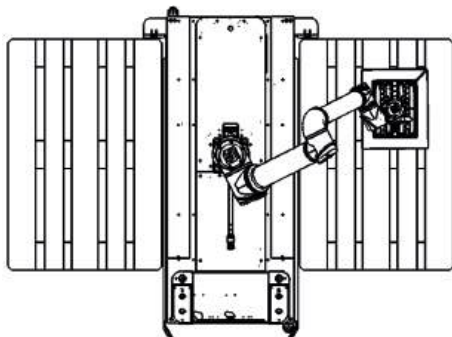

Pallet Bays: 2

Power Supply: 400V, 50 Hz  
16A

Power Consumption (max): Dependent on robot type & optional lifting axis: UR 20 & UR 30 1,020W; UR 10 885W (incl. lifting axis +480W)

Compressed Air: 6 bar (consumption resp. to gripper)

Interfaces: I/O  
(freely available, if no conveyor is combined) MODBUS TCP  
Emergency-Stop (In & Out)  
2x Digital Input; 2x Digital Output  
1x Analogue Output  
Power (230V or 400V)

Safety: KAT. 3 PId, CE conformity  
Following TS 15066  
Power & Force Limitation (EN ISO 10218-1)  
Tactile Safety Contact Buffer (EOA)

Stacking Heights (max): Up to 2,400 mm (UR 20 with lifting axis)

Cycle Speed: Dependent on product weight, pack pattern & pallet type 4-36 packs/min.

**SCOPE OF DELIVERY**

- 1x Compact Palletizing Unit with switch cabinet & control desk
- 1x Cobot Universal Robots (at choice UR 10, UR 20 or UR 30)
- 1x End-of-Arm Tool at choice (e.g. soft areal vacuum gripper or mechanical gripper)
- 1x Tactile Safety Contact Buffer for gripper housing
- 1x Set flexible cable/hose guide for robot
- 1x Palletizing Software for free packing patterns & sort confectioning

**OPTIONS**

Customized or adjustable multiple grippers; conveyor (basic or accumulation roller version); telescopic lifting axis; image processing; machine signalling lights; safety scanner; OPC UA or Profinet interface; special stainless steel construction

#heroes of  
efficiency



## AUTONOMOUS INTRALOGISTICS CAN BE SO MUCH MORE EFFICIENT

### OUR INTEGRATOR SERVICES FOR YOU

 **INDIVIDUAL CONSULTING,  
SAFETY & CONCEPTION**

 **TEST INSTALLATION**

 **FLEET MANAGEMENT**

 **COMMISSIONING,  
MAINTENANCE & SERVICE**

 **PERSONNEL TRAININGS &  
USER ADVISORY**

### PALLETIZING RETHOUGHT FOR YOUR ECONOMIC EFFICIENCY AND HEALTH OF YOUR EMPLOYEES

What the trade press says about our solution:

*,Unrivalled easy.'*

(pharmaindustrie-online, 11 March 2024)

*,Safe, flexible and efficiency-enhancing.'*

(Industrial Production, edition 03/2024)

### SUITABLE FOR ALL INDUSTRIES

• AUTOMOTIVE • MECHANICAL ENGINEERING • ELECTRONICS • FMCG  
• FOOD & BEVERAGE • HEALTHCARE • PHARMACEUTICAL • YOURS

### GET TO KNOW US!

As a manufacturer-independent integrator of autonomous transport systems we supply the industry-adapted and customized solution for the automation of your intralogistics tasks in industry, services, trade and commerce.

**Get your company's logistics fit for the future with us now!**



 **MOBILE ROBOTS**

Gewerbepark Grünewald 1 D - 58540 Meinerzhagen  
P. +49 (0)2354 907 25-0 / [mail@mobile-robots.de](mailto:mail@mobile-robots.de)

CREATING INDUSTRIAL ENVIRONMENTS OF THE FUTURE. TODAY.